

MD330U Series PTZ Camera

User Manual



How to Clean and Disinfect

Warning**Risk of personal injury**

Do not use cleaning agents containing phenol, as phenol may cause skin burns if not rinsed thoroughly and does not contain sufficient cleaning or disinfectant properties.

Caution

1. The camera is designed for easy cleaning and disinfection.
2. Before cleaning the camera, disconnect it from the power source.
3. Cleaning procedures should only be carried out by personnel familiar with camera operation.
4. Do not spray cleaning fluid, especially water, into any internal electrical equipment or parts of the camera to avoid possible short circuits, corrosion, malfunction and electrical shock hazards to users or service personnel.
5. Corrosive cleaning agents may cause discoloration or damage the camera. Before using any cleaning agent, test it in an inconspicuous area.

When

Clean the camera before and after use.

Steps

1. Disconnect the camera from a power source.
2. Cleaning personnel must wear cleaning gloves.
3. Before using cleaning alcohol, make sure it has not expired.
4. Use a cleaning cloth dampened with cleaning alcohol (75%).
5. Wipe any surface that may come into contact with the camera.
6. After wiping the camera, avoid contact with bare hands.

Frequency

No regular cleaning is required. Clean before and after use.

Precautions for Use

AVer does not accept any responsibility for accident or damage during installation if users do not follow the procedures described in this manual.

Indications for Use

The AVer MD330U Series is a high definition medical grade PTZ camera designed for physicians. It's a non-contact unit that can be operated by physicians without physical contact with patients. The units can be used to document and update patients' injuries by taking snapshot images or record video clips. The unit is suitable for use in hospital examination rooms and similar medical environments.

To installation and operation personnel

The required information including the unit's hardware parts, operations and important notice has been written and illustrated in this manual. Except for the information in this manual, no special skills, training and knowledge are required for the operators. Read the installation instructions and content of the manual thoroughly and perform the operation correctly and safely. Please also refer to the <Troubleshooting> chapter when you encounter common problems while using this unit. For more technical support, please contact AVer's technical support (refer to [More Help](#)).

● Warning on installation locations

This unit is for indoor use only. Do not install nor use the unit in the following locations to avoid malfunction and/or problems in operation.

- In outdoor locations where the unit will be exposed to direct sunlight.
- In locations where the unit would be directly exposed to rain or water.
- Extremely cold or hot locations (Operating temperatures: 0°C to +35°C; Humidity: 20% to 80%).
- On walls where the unit would be installed sideways.
- At sea, in coastal areas or in locations where corrosive gases are emitted.
- Locations subject to strong vibrations (this unit is not designed to be used in vehicles).

● To ensure the unit perform stably over a prolonged period

- Do not use this unit in a location with high temperature and humidity levels, which may cause its parts to deteriorate and shorten its service life.
- Do not subject the unit to sudden changes in temperature. Keep a cooling unit or heating unit away from this unit.
- Do not leave the unit with the camera facing the sun.

● Always use the supplied power adapter and power cord to connect the unit to the power outlet

- Before installation, always disconnect the power supply of this unit.
- Install this unit near the main power outlet. Ensure the power plug can be plugged into and unplugged from the power outlet easily.
- The length of the power cord is less than 3-meter.

- Do not place the camera where the cord can be stepped on as this may result in fraying or damage to the lead or the plug.

- **Power off the unit**

- This unit does not have a power switch. Disconnect the power plug from the power outlet before proceeding with maintenance, cleaning or any emergency situations.

- **Maintenance**

- Designate the responsibility for keeping areas clean to staff members and clean regularly.
- This unit does not have a power switch. Disconnect the power plug from the power outlet before proceeding with maintenance.
- Regular maintenance keeps your unit productive and safe. Check all machine parts carefully, including the detachable camera head, camera body and remote control.
- When the surfaces of the machine parts become dirty, follow the instructions described in the Cleaning sector to clean the unit.

- **When installing, transporting or disposing of the unit**

- Be absolutely sure to hold it by its pedestal area at the bottom with both hands. Do not grab the camera head, nor the camera head holder.

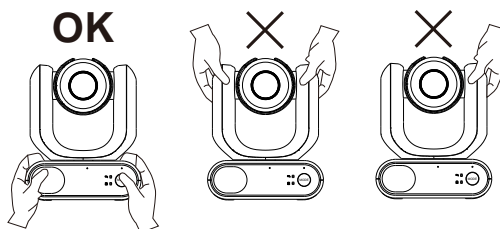









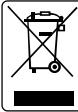

- **Dispose of the unit**

- When the unit is no longer going to be used, ensure to turn off the unit and dispose of it properly.
- When you dispose of the unit or accessories, you must obey the laws in the relative area or country and the regulations in the relative hospital regarding environmental pollution.

Symbols on this Product

The symbols on this product, including the accessories, represent the following.

	<p>The WEEE symbol. This symbol indicates that this product must not be disposed of with your other household waste. Instead, you need to dispose of the waste equipment by handing it over to a designated collection point for the recycling of waste electrical and electronic equipment. For more information about where to drop off your waste equipment for recycling, please contact your household waste disposal service or the shop where you purchased the product.</p>
	<p>The CE compliance logo. This logo indicates that the product conforms to the relevant guidelines/standards for the European Union harmonization legislation.</p>
	<p>The FCC compliance logo. This logo indicates that the product conforms to Federal Communications Commission compliance standards.</p>
	<p>The UKCA (UK Conformity Assessed) symbol. This symbol indicates that a product placed on the Great Britain market meets the UKCA Marking requirements.</p>
	<p>The RCM compliance logo. This logo indicates that the product conforms with Australian RCM guidelines.</p>
	<p>This logo is intended to alert the users to the presence of un-insulated "dangerous voltage" within the product's enclosure that may be of sufficient magnitude to constitute a risk of electric shock to persons.</p>
	<p>This logo is intended to alert the users to the presence of important operating and maintenance (servicing) instructions in the literature accompanying the appliance.</p>
	<p>The China RoHS symbol. The figure of this symbol represents the number of years during which no hazardous substances would leak or mutate under normal conditions of use.</p>
	<p>The ISO 7010-M002 symbol. Refer to instruction manual/booklet.</p>
	<p>The alternating current symbol. This symbol indicates that the power input/output for the product is alternating current.</p>
	<p>The direct current symbol. This symbol indicates that the power input/output for the product is direct current.</p>

Federal Communication Commission Interference Statement

This device complies with Part 15 of the FCC Rules. Operation is subject to the following two conditions: (1) This device may not cause harmful interference, and (2) this device must accept any interference received, including interference that may cause undesired operation.

This equipment has been tested and found to comply with the limits for a Class B digital device, pursuant to Part 15 of the FCC Rules. These limits are designed to provide reasonable protection against harmful interference in a residential installation. This equipment generates, uses and can radiate radio frequency energy and, if not installed and used in accordance with the instructions, may cause harmful interference to radio communications. However, there is no guarantee that interference will not occur in a particular installation. If this equipment does cause harmful interference to radio or television reception, which can be determined by turning the equipment off and on, the user is encouraged to try to correct the interference by one of the following measures:

- Reorient or relocate the receiving antenna.
- Increase the separation between the equipment and receiver.
- Connect the equipment into an outlet on a circuit different from that to which the receiver is connected.
- Consult the dealer or an experienced radio/TV technician for help.

FCC Caution: Any changes or modifications not expressly approved by the party responsible for compliance could void the user's authority to operate this equipment.

This Class B digital apparatus complies with Canadian ICES-003. Cet appareil numérique de la classe B est conforme à la norme NMB-003 du Canada.

Remote Control Battery Safety Information

- Store batteries in a cool and dry place.
- Do not throw away used batteries in the trash. Properly dispose of used batteries through specially approved disposal methods.
- Remove the batteries if they are not in use for long periods of time. Battery leakage and corrosion can damage the remote control. Dispose of batteries safely and through approved disposal methods.
- Do not use old batteries with new batteries.
- Do not mix and use different types of batteries: alkaline, standard (carbon-zinc) or rechargeable (nickel-cadmium).
- Do not dispose of batteries in a fire.
- Do not attempt to short-circuit the battery terminals.

Warning

- To avoid the risk of electric shock, this equipment must only be connected to a supply mains with protective earthing.
- Do not modify this equipment without authorization of the manufacturer.

Caution



Possibly hazardous optical radiation emitted from this product. Do not stare at operation lamp. May be harmful to the eyes.

Ce produit peut émettre un rayonnement lumineux dangereux. Ne regarder pas directement dans la lumière. Peut être dangereux pour les yeux.

DISCLAIMER

No warranty or representation, either expressed or implied, is made with respect to the contents of this documentation, its quality, performance, merchantability, or fitness for a particular purpose. Information presented in this documentation has been carefully checked for reliability; however, no responsibility is assumed for inaccuracies. The information contained in this documentation is subject to change without notice.

In no event will AVer Information Inc. be liable for direct, indirect, special, incidental, or consequential damages arising out of the use or inability to use this product or documentation, even if advised of the possibility of such damages.

TRADEMARKS

“AVer” is a trademark owned by AVer Information Inc. Other trademarks used herein for description purpose only belong to each of their companies.

COPYRIGHT

©2023 AVer Information Inc. All rights reserved. | June 29, 2023

All rights of this object belong to AVer Information Inc. Reproduced or transmitted in any form or by any means without the prior written permission of AVer Information Inc. is prohibited. All information or specifications are subject to change without prior notice.

More Help

For FAQs, technical support, software and user manual download, please visit:

Headquarters

Download Center: <https://www.aver.com/download-center>

Technical Support: <https://www.aver.com/technical-support>

USA Branch Office

Download Center: <https://www.averusa.com/pro-av/support>

Technical Support: <https://averusa.force.com/support/s/contactsupport>

Europe Branch Office

Download Center: <https://www.avereurope.com/download-center>

Technical Support: <https://www.avereurope.com/technical-support>

Contact Information

Headquarters

AVer Information Inc.

<https://www.aver.com>

8F, No.157, Da-An Rd., Tucheng Dist., New Taipei City 23673, Taiwan

Tel: +886 (2) 2269 8535

USA Branch Office

AVer Information Inc., Americas

<https://www.averusa.com>

668 Mission Ct., Fremont, CA 94539, USA

Tel: +1 (408) 263 3828

Toll-free: +1 (877) 528 7824

Technical support: support.usa@aver.com

Europe Branch Office

AVer Information Europe B.V.

<https://www.avereurope.com>

Westblaak 134, 3012 KM, Rotterdam, The Netherlands

Tel: +31 (0) 10 7600 550

Technical support: eu.rma@aver.com

Japan Branch Office

アバー・インフォメーション株式会社

<https://jp.aver.com>

〒160-0023 日本東京都新宿区西新宿 3-2-26 立花新宿ビル 7 階

Tel: +81 (0) 3 5989 0290

テクニカル・サポート: <https://jp.aver.com/technical-support>

Vietnam Branch Office

Công ty TNHH AVer Information (Việt Nam)

Tầng 5, 596 Nguyễn Đình Chiểu, P.3, Quận 3,

Thành phố Hồ Chí Minh 700000, Việt Nam

Tel: +84 (0)28 22 539 211

Contents

How to Clean and Disinfect	2
Precautions for Use.....	3
Overview.....	1
Package Contents.....	1
Optional Accessories	1
Connections.....	2
LED Indicators	3
Dimensions	4
Pan and Tilt Angle.....	4
Mode Switch	5
Installation.....	6
Table Mount.....	6
Device Connection	7
Remote Control.....	9
Shortcuts	10
Set Up the Camera.....	11
OSD Menu	11
IP Address Setup	11
OSD Menu Tree	13
Web Setup	16
Access the Web Interface of the Camera.....	16
Live View.....	18
AI Setting	20
Detection.....	20
Tracking	21
Camera Settings	22
Video & Audio.....	24

Network	26
System	28
AVerCamera Setting Tool	30
Specification	31
Troubleshooting.....	34
Appendix	36
VISCA RS-232 Command Table	36
VISCA over IP Settings	44
CGI Command	45

Overview

The MD330U Series PTZ Camera is a dual-mode medical grade camera designed with a detachable camera head. It comes in two models: MD330U (fill light) and MD330UI (infrared night vision).

Package Contents

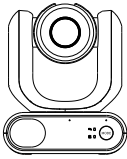

Camera

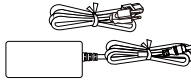

Power Adapter & Power Cord



Remote Control

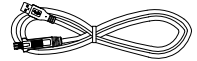

USB 3.0 Type-B to Type-A Cable (1.5m)

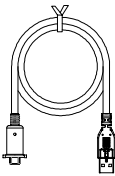

USB 3.0 Type-C to Type-A Camera Head Cable (180cm)



1/4"-20, L=7.5mm Table Mount Screw (x2)



QR Code Card

Optional Accessories



3.5mm to D-Sub 9-pin RS-232 Adapter

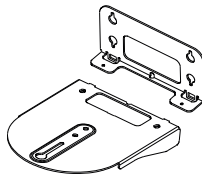

Wall Mount Bracket (Black/White)

Connections

- The camera head must be detached or installed in Handheld Mode. Use the mode button to switch to between modes.
- Connect only the camera head cable to the USB Type-A port. **DO NOT** connect any USB devices to the USB Type-A port. Doing so may cause electrical damage to your USB devices.

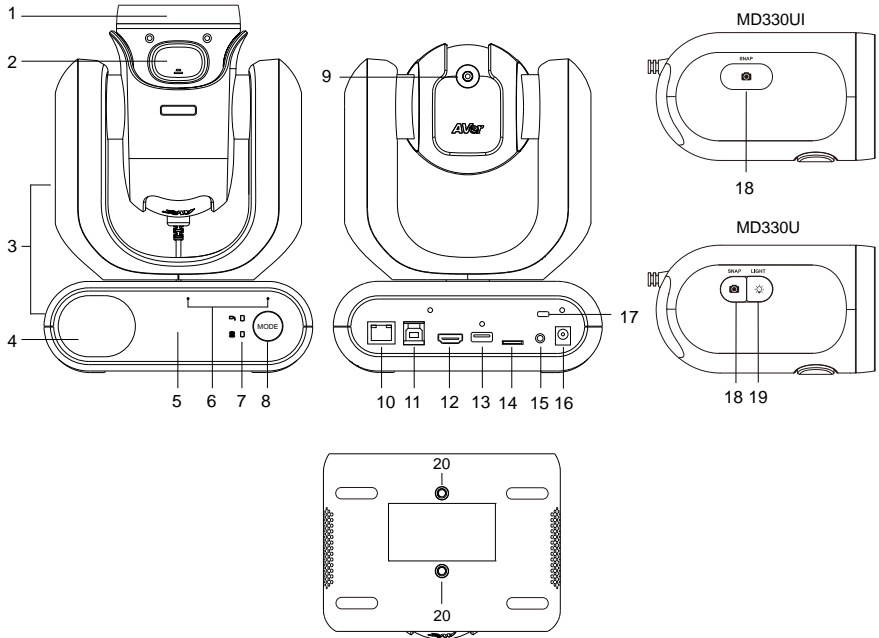

- | | | |
|---|-------------------------|-----------------------|
| 1. Camera Head | 8. Mode Button | 16. DC 12V |
| 2. Latch Button | 9. Camera Head Cable | 17. Kensington Lock |
| 3. Camera Body | 10. LAN | 18. Snapshot Button |
| 4. Speaker | 11. USB 3.0 Type-B | 19. Fill Light Button |
| 5. IR Sensor | 12. HDMI | 20. Screw Holes |
| 6. Microphone Array | 13. USB Type-A (Note 2) | Screw size: 1/4"-20 |
| 7. LED Indicators:
Handheld/Standard | 14. microSD (32GB/SDXC) | L=7.5mm (included) |
| | 15. RS-232 | |

LED Indicators

The illumination of the indicators confirms the camera mode.



Standard Mode



● (default)



●

Handheld Mode



Color	Status	Pattern
Flashing orange	Booting up	●●
Solid blue	Normal	●
Solid orange	Standby	●
Flashing orange slowly (1-sec interval)	Muted	●
Flashing orange once	Taking a snapshot	⊙
Flashing orange (0.5-sec interval)	Recording	⊙
Solid purple	OSD menu is turned on.	●
Flashing purple	Updating firmware	●●

- Both indicators flash.
- The indicator is mode-sensitive.
- ⊙ The spare indicator flashes.

Dimensions

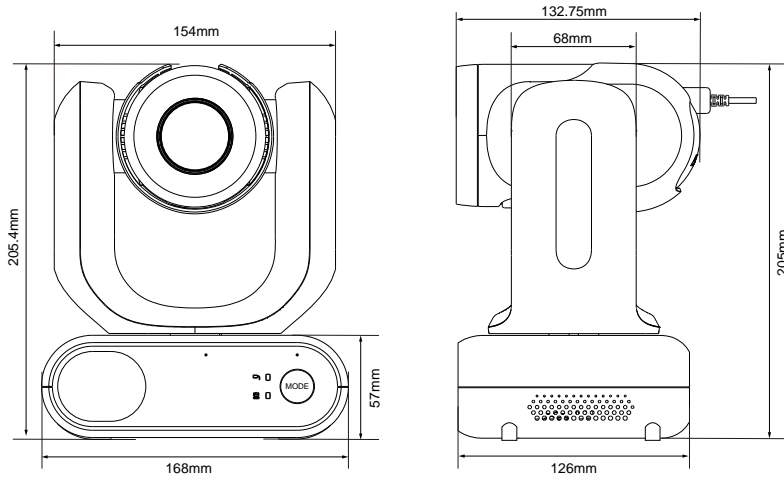

Pan and Tilt Angle

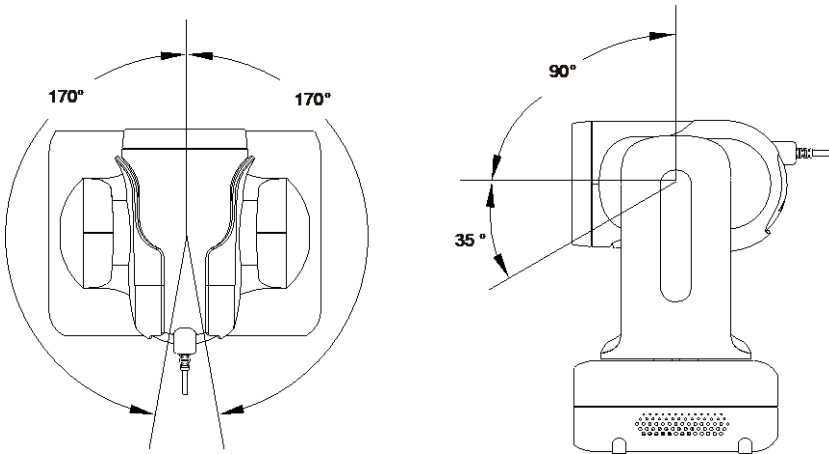

Mode Switch

The camera head must be detached or installed in Handheld Mode. Use the mode button to switch between modes and the LED indicators to confirm your current mode.

Detach Camera Head

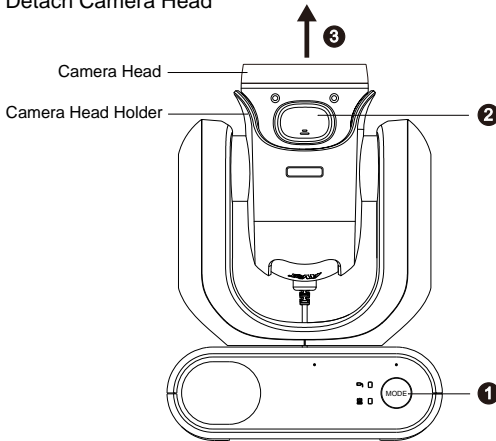

Install Camera Head

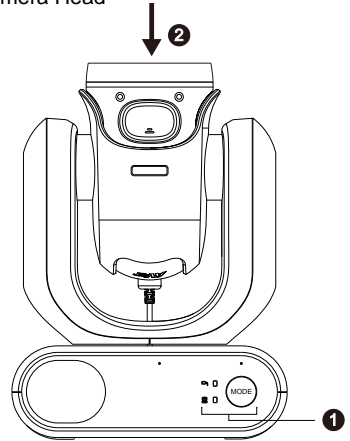

To detach the camera head:

1. Press the mode button to switch from Standard Mode to Handheld Mode. The camera head will automatically turn up.
2. Press the latch button.
3. Remove the camera head from the camera head holder.

To install the camera head:

1. Make sure the camera is in Handheld Mode. If not, press the mode button to switch from Standard Mode to Handheld Mode.
2. Insert the camera head in the camera head holder until you hear a click.

To take snapshots in Handheld Mode:

1. Make sure a microSD card has been inserted in the slot.
2. Select a focus distance on the web interface (see [Camera Control](#) > Focus Near Limit).
3. Long press (1 second) the snapshot button to take snapshots. Short press the snapshot button to adjust the focus.

To turn on the fill light in Handheld Mode (MD330U):

1. Press the fill light button on the camera head to turn it on, and press the button repeatedly to cycle through 3 brightness levels (On > Low > Medium > High > Off).
2. With the fill light on, the closest shooting distance should be 4.5 cm.

Installation

Table Mount

1. Hold the camera by its pedestal with both hands. Do not grab the camera head, nor the camera head holder.

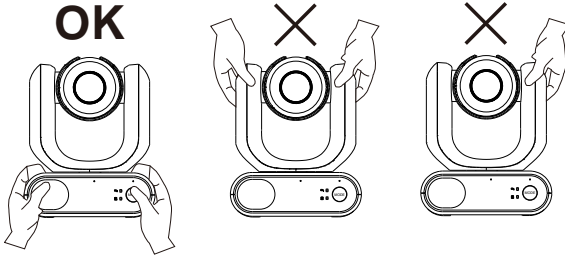

2. Place the camera on a flat surface that supports 2kg min.
3. Manage all cables to prevent tip-overs or entanglement.
4. Secure the camera in place with the included screws.

Device Connection

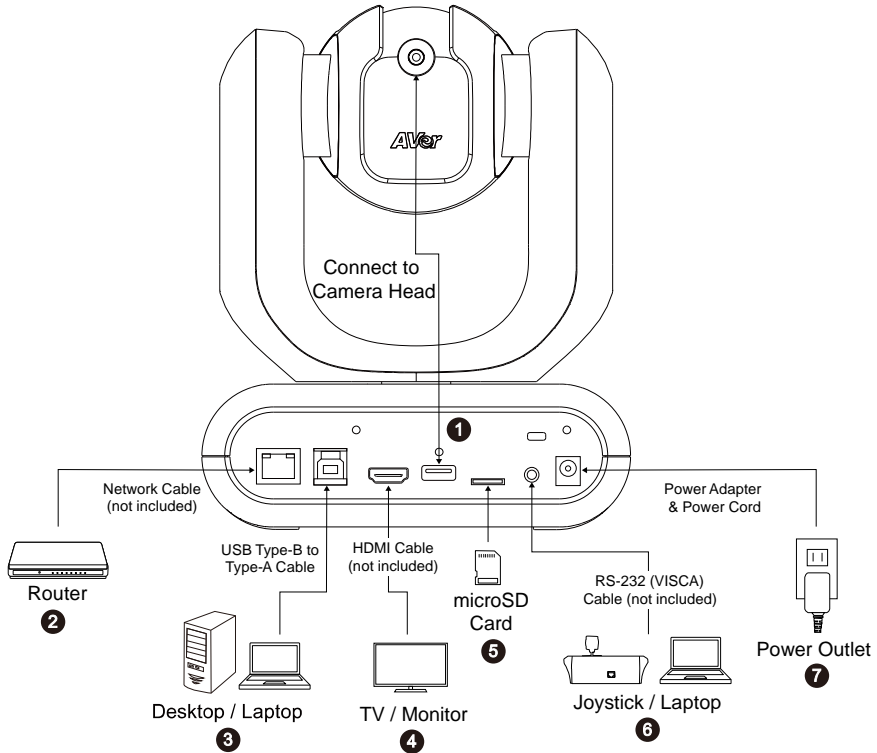

- 1. USB Type-A:** Connect only the camera head cable to the USB Type-A port as illustrated. Plug in the camera head cable before powering on the camera.

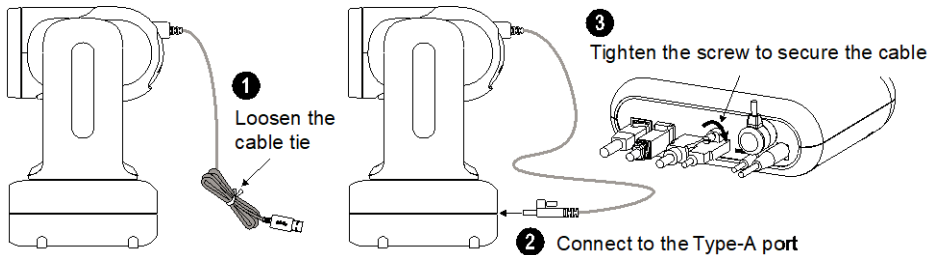

- 2. LAN:** Connect the camera to an IP route (Note 1).
- 3. USB Type-B:** Connect the camera to a desktop or laptop for video transmission when using third-party video conferencing software such as Skype or Teams (Note 1).
- 4. HDMI:** Connect the camera to a TV or a monitor to display video output. The camera and the connected TV or monitor must have grounding design. (Note 1).

5. **microSD Card:** Insert a microSD card to store captured images or recordings (Note 1 and 2).

- Compatible microSD Cards

Brand	Kingston, SanDisk, Samsung, Lexar
Speed Class	C10, U1, U3, V10, V30
Capacity	16G, 32G
Format	FAT32, exFAT

6. **RS-232:** Connect the camera to a Joystick or laptop to control the camera. You can optionally purchase the RS-232 Adapter. The PIN definition is shown as below (Note 1).

RS-232 Adapter (3.5mm to D-Sub 9-pin)

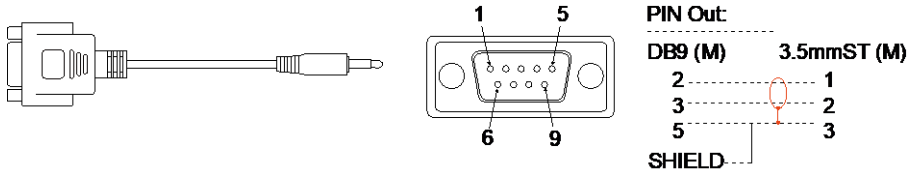

7. **Power:** The camera and the connected TV or monitor must have grounding design. Use the supplied power adapter and power cord to connect the camera to a power outlet and make sure the power cord of the TV or monitor supports the grounding plug.

[Note]

1. Accessory equipment connected to the analog and digital interfaces must be in compliance with the respective nationally harmonized IEC standards (i.e. IEC 60950 for data processing equipment, IEC 60065 for video equipment, IEC 61010-1 for laboratory equipment, and IEC 60601-1 for medical equipment.) Furthermore all configurations shall comply with the requirements of the system in standard IEC 60601-1. Everybody who connects additional equipment to the signal input part or signal output part configures a medical system, and is therefore, responsible that the system complies with the requirements of the system in standard IEC 60601-1. The unit is for exclusive interconnection with IEC 60601-1 certified equipment in the patient environment and IEC 60XXX certified equipment outside of the patient environment. If in doubt, consult the technical services department or your local representative.
2. Please insert a microSD card to the card slot before using the Snapshot or Recording functions. To access the microSD card, please refer to **Mass Storage** in the <System> chapter for more details. For the recommended microSD cards, please refer to the <Compatible microSD Cards> chapter.

Remote Control

- To open the OSD menu, press and hold **Menu**  for 3 seconds.
- To disable remote control, open the OSD menu, go to **System > Camera Selector > Disable Remote**.
- To resume remote control, press 6 six times (666666) to reset the camera to factory default settings.

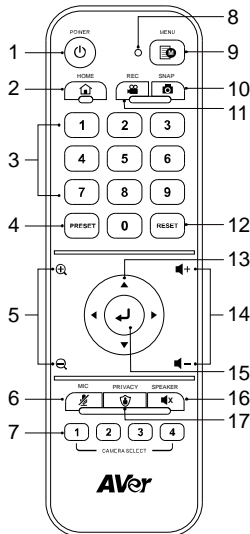







Model: LY033
AAA batteries (x2)

Name	Function
1. Power	Short press to turn Standby Mode on or off.
2. Home	Move the camera to the Home position.
3. Number Pad	<ul style="list-style-type: none"> ● Press buttons 0~9 to move the camera to the pre-configured preset positions. ● Use the buttons to set up preset positions 0~9.
4. Preset	<p>Use the Preset, Number and Direction Buttons to set up preset positions.</p> <ol style="list-style-type: none"> 1. Use the Direction Buttons to navigate a position. Optionally use the "Zoom +" or "Zoom -" buttons to zoom in/out the image. 2. Press and hold Preset, then press the Number Buttons (0~9) to save this preset position.
5. Zoom +/-	Press to zoom in or zoom out the images.
6. MIC	Press to mute the microphone. Press again to unmute.
7. Camera Select	Select a camera to operate. Specify a number in the OSD menu: System > Camera Selector .
8. Remote Control LED	When pressing the buttons on the remote control, the LED will light red.
9. Menu	Press and hold for 3 seconds to open the OSD menu. Edit this setting in the OSD menu: System > Trigger OSD .
10.Snap	Press to take a snapshot image. The images will be stored in the microSD card.
11.Rec	Press to start recording to the micro SD card. Press the button again to stop recording.
12.Reset	Use the Reset and Number Buttons to cancel a pre-configured preset position. Press and hold Reset, then press the Number Buttons (0~9).

13.Direction	Use the Direction Buttons to navigate the live view.
14.Volume +/-	Press to adjust the volume up or down.
15.Enter	When camera is on: Press Enter to adjust focus once. When accessing the OSD menu: Press Enter to confirm the selection or make a selection.
16.Speaker	Press to mute the speaker. Press again to unmute.
17.Privacy	Press to enter the Privacy mode. The camera will move to the Privacy position and microphone will be off.

Shortcuts







Press	To
Menu  for 3 seconds	Open the OSD menu.
Menu 	Close the OSD menu.
Home 	Close the OSD menu and return the camera to the Home position.
Menu  then Zoom 	MD330U: Cycle through 3 brightness levels (On > Low > Medium > High > Off). MD330UI: Switch between Day mode and Night mode.
Menu  then Zoom 	MD330UI: Switch between Day mode and Auto mode.
5 five times (55555) <i>Firmware 1.1.1005.1 or later</i>	Turn on DHCP.
6 six times (666666) <i>Firmware 1.1.1030.0 or later</i>	Reset the camera to factory default settings.
8 eight times (88888888) <i>Firmware 1.1.1005.1 or later</i>	Set the camera's static IP address to 192.168.1.168.

Set Up the Camera

You can configure camera settings using the OSD menu or the web interface of the camera.

OSD Menu

To access the OSD menu, connect the camera to a monitor or TV using an HDMI cable, and then use the supplied remote control to operate the OSD menu.

Press and hold the menu button  for 3 seconds to bring up the OSD menu. Use directional buttons     to select and press Enter  to confirm settings.

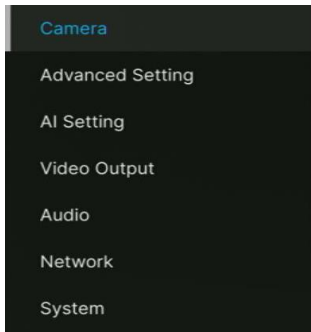

IP Address Setup

Static IP



1. Press the menu button  on the remote control to bring up the OSD menu.
2. Go to **Network > Static IP**.

[Note] Turn the **DHCP** off before setting up static IP (**Network > DHCP > OFF**).

3. Select the **IP Address**, **Gateway**, **Netmask**, and **DNS** to configure. Press Enter  and use the number buttons to enter the value.



DHCP

1. Press the menu button  on the remote control to bring-up the OSD menu.
2. Select **Network** > **DHCP** > **On**.
3. Press Enter  to confirm setting.

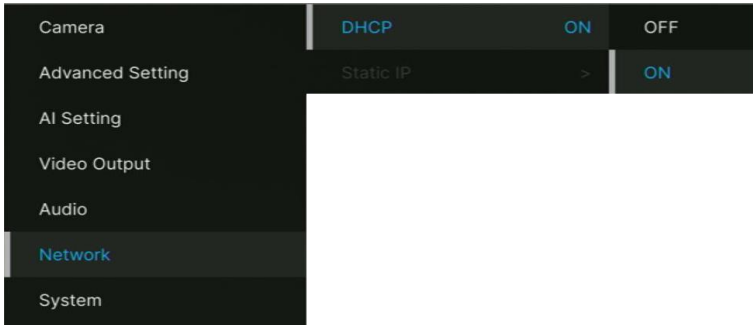

4. After turning the **DHCP** on, you can go to **System** > **Information** to view the IP address.

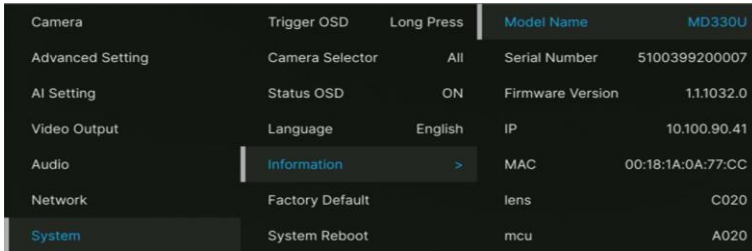

The screenshot shows the OSD menu with the following structure:

- Camera
- Advanced Setting
- AI Setting
- Video Output
- Audio
- Network
- System** (highlighted)

Under the **System** menu, the following options are visible:

- Trigger OSD
- Long Press
- Information** (highlighted) >
- Camera Selector
- Status OSD
- Language
- English
- Factory Default
- System Reboot

The **Information** screen displays the following data:

Model Name	MD330U
Serial Number	5100399200007
Firmware Version	1.1.1032.0
IP	10.100.90.41
MAC	00:18:1A:0A:77:CC
lens	C020
mcu	A020

OSD Menu Tree

1 st Layer	2 nd Layer	3 rd Layer	4 th Layer
Camera	Exposure Mode	Full Auto	Exposure Value
			Gain Limit Level
			Slow Shutter
		Shutter Priority	Exposure Value
			Shutter Speed
			Gain Limit Level
		Iris Priority	Exposure Value
			Iris Level
			Gain Limit Level
			Slow Shutter
		Manual	Iris Level
			Shutter Speed
	Gain Level		
	White Balance	Auto	
		ATW	
		Indoor	
		Outdoor	
		One push trigger	
		Manual	R gain
		B gain	
	Pan Tilt Zoom	Preset Speed	5, 25, 50, 100, 150, 200
		Preset Accuracy	Off / On
		Sensor Zoom	Off / On
		Sensor Zoom Limit	x2
		Pan Speed	1~24
		Tilt Speed	1~24
		Zoom Speed	Low / High
		P/T Spd. Relative Z Ratio	Off / On
		Pan L/R Dir. Switch	Off / On
	Noise filter	Off / Low / Middle /	

1 st Layer	2 nd Layer	3 rd Layer	4 th Layer
		High	
	Saturation	0 1 2 3 4 5 6 7 8 9 10	
	Contrast	0 1 2 3 4	
	Sharpness	0 1 2 3	
	Mirror	OFF / ON	
	Flip	OFF / ON	
Advanced Setting	Control	Type	RS232
		Protocol	VISCA
		Camera Address	1 2 3 4 5 6 7
		Baud Rate	2400 / 4800 / 9600 / 38400
	IR Cut Filter	Auto / Day / Night	
	IR Cut Sensitivity	Low / Middle / High	
AI Setting	Tracking Setting	Tracking	On/Off
		Tracking Preset	Save
		Tracking Mode	Face/Eyes
		Tracking Range	Close / Medium / Wide
		Timeout to Preset	3/5/7/10 sec
	Detection Setting	Detection	On/Off
		Detection Mode	Body
Video Output	Frequency	60	
		59.94	
		50	
	Resolution	1080p60	
		1080p59.94	
		1080p30	
		1080p29.97	
		1080p50	
1080p25			
Audio	Audio Input	Noise Suppression	OFF/ NR DSP/ NR/ NR+BF/ NR Strong
		Audio Beam Forming	30,50,70,90,110,130

1 st Layer	2 nd Layer	3 rd Layer	4 th Layer
		Audio In Volume	Mute / 1~10
	Audio Output	Output Type	Speaker/HDMI/Both
		Output Volume	Mute / 1~10
Network	DHCP	OFF	
		ON	
	Static IP	IP Address	192.168.1.168
		Gateway	192.168.1.254
		Mask	255.255.255.0
DNS	8.8.8.8		
System	Trigger OSD	Click Menu to open, Press Menu 3 sec	
	Camera Selector	1,2,3,4, All channel, Disable Remote	
	Status OSD	OFF	
		ON	
	Language	English / 中文 / 日本語	
	Information	Model Name	MD330U(I)
		Serial number	xxxxxxxxxxxxxx
		Firmware Version	0.0.0000.00
		IP	192.168.1.168
		MAC	00:18:1a:04:9e:81
		lens	xxxx
		mcu	xxxx
		SD Total (MB)	
		SD Free (MB)	
	Recording Status	Stopped / xx:xx:xx (record timer)	
	Factory Default	Off / On	
System Reboot	Off / On		

Web Setup

Connect the camera from a remote site through the internet.

Access the Web Interface of the Camera

To access the Web interface of the camera, you have to find the IP address of the camera using **AVer IPCam Utility** or **AVer PTZ Management** software.

Accessing the Camera via AVer IPCam Utility

To find the IP address of your cameras using the IPCam Utility installer, follow the steps below.

1. Download the IPCam Utility from <https://www.aver.com/download-center> and run the IPCam Utility.
2. Click **Search**, and all available devices will be listed on the screen.
3. Select a camera from the list, the camera info will be displayed in the Settings field.

[Note] The default network of the camera is Static IP (192.168.1.168) and default ID/Password are **admin/admin**. If you want to configure the network to DHCP, input the ID/Password in the **Login** field, select the “camera model” on the list, select “DHCP” and then click the **Apply** button.

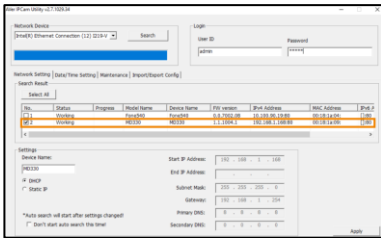

4. To access the Web interface, double-click on the IP address in the IPv4 Address column. For the first-time user, you will be prompted with a Login window to change the ID and password.

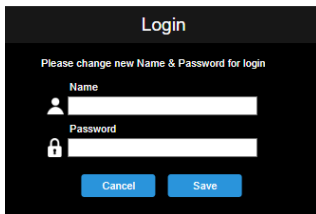

5. Login with the new ID/Password, the Web interface of the camera will be displayed (Chrome browser). Please refer to the <[Live View](#)> chapter for more details.

[Note] If IPCam utility cannot find the camera, please check following:

1. Please make sure the Ethernet connection of camera is well connected.
2. The camera and PC (IPCam Utility) are in the same LAN segment.

Accessing the Camera via AVer PTZ Management

To find the IP address of your cameras using the AVer PTZ Management, follow the steps below.

1. Download the AVer PTZ Management software from <https://www.aver.com/download-center>
2. Download the Windows program and install it.
3. After setting up the user ID and password, log in to the software (default User Name/Password: admin/admin).

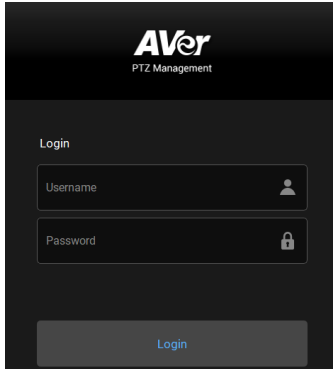

4. On the Main page of PTZ Management, click **Setup > Add** and then click **Auto Search**. The cameras connected on the same LAN with the computer will be displayed.

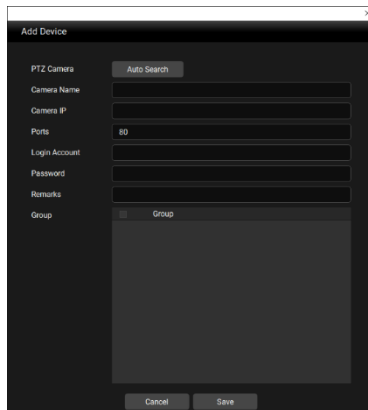
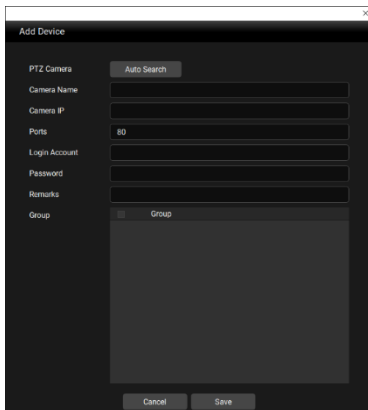





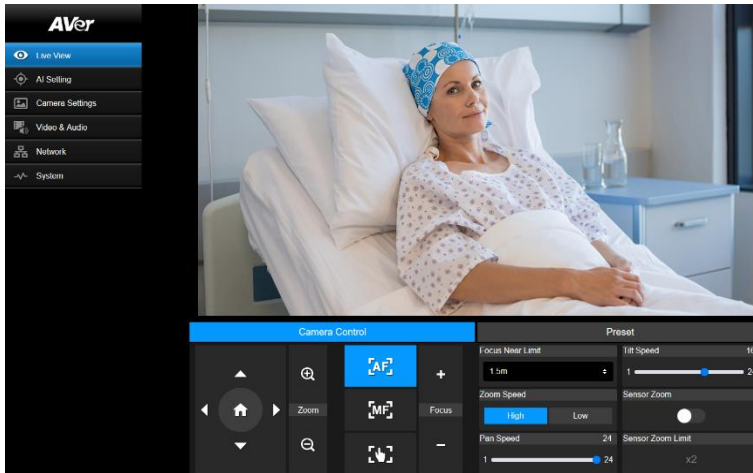

5. Click on the camera and input the camera ID and Password to add the camera to the device list (default ID/Password are **admin/admin**). Click the **Go to Web** button to access the Web interface of the camera.

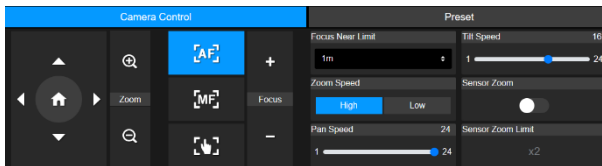
Live View



Camera Control



Item	Description
Pan and Tilt Controls 	Position the camera. <ul style="list-style-type: none"> ● Drag the slider to adjust Pan Speed and Tilt Speed.
Home Position 	Move the camera to the Home position.
Zoom 	<ul style="list-style-type: none"> ● Zoom in or zoom out the live view and select Zoom Speed. ● Turn on Sensor Zoom to enable sensor zoom. ● Up to 30X optical zoom and 2X sensor zoom (Sensor Zoom Limit).
Focus +-	<ul style="list-style-type: none"> ●  Auto Focus: Click to automatically focus. ●  Manual Focus: Click to manually focus. Adjust the focus with +- buttons. ●  One Push Focus: Click to automatically focus once. ● Focus Near Limit: Set up the nearest focus limit.

Preset

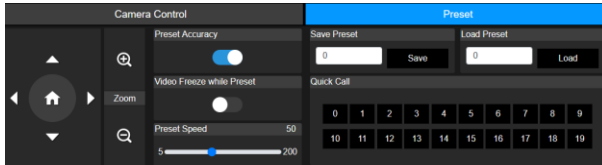

Item	Description
Save Preset	<ol style="list-style-type: none">1. Position the camera using pan, tilt and zoom controls.2. Enter a preset number (0~255) in the Save Preset field and click Save.
Load Preset	<ol style="list-style-type: none">1. Enter a preset number (0~255) in the Load Preset field and click Load.2. Or click a preset number (0~19) in the Quick Call section.
Preset Accuracy	Turn on to improve the accuracy of moving to presets.
Video Freeze while Preset	Turn on to display only the live view from presets. The live view from the moving path will not be displayed.
Preset Speed	Adjust the camera speed when moving to presets.

AI Setting

Detection and Tracking can't be turned on at the same time.

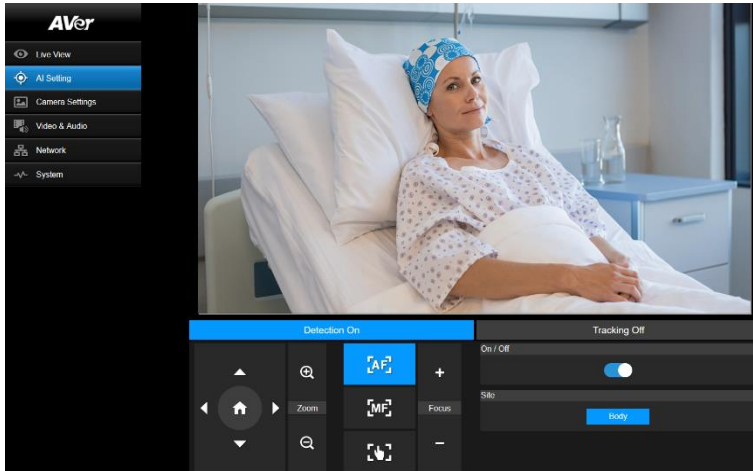

Detection

Click the **On/Off** toggle to turn on body detection.

- The camera will frame human bodies in view with blue AI bounding boxes.
- Use API to report AI bounding box coordinates to third-party software.

Tracking

Manually adjusting pan, tilt and zoom controls during tracking will turn the function off.

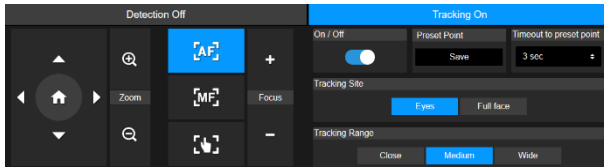

1. Position the camera using pan, tilt and zoom controls and then click **Save** to save a **Tracking Preset**. The default is the Home position.
2. From the **Timeout to preset** drop-down list, select an interval before the camera returns to the tracking preset when no one is in view. The default is 3 seconds.
3. Click the **On/Off** toggle to turn on Eyes Tracking when a face is in view.
 - One person: The camera will automatically track and zoom in on the face.
 - Multiple people: The camera will mark faces in squares. Select a face to automatically track and zoom in on by clicking a square.
4. Choose the **Tracking Site** and **Tracking Range**.

Camera Settings

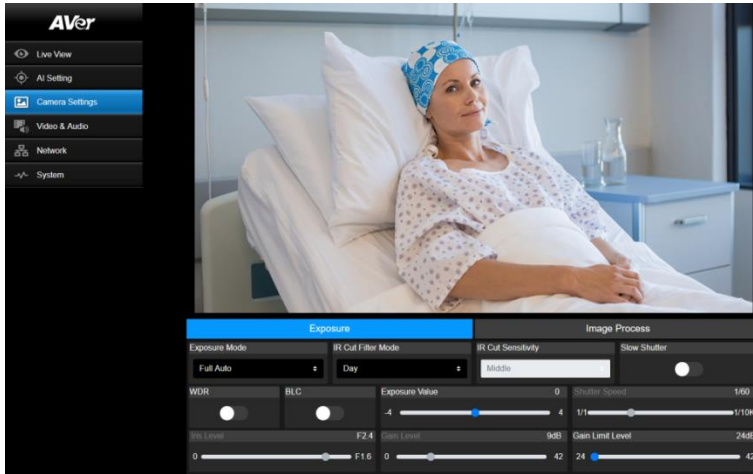

Exposure

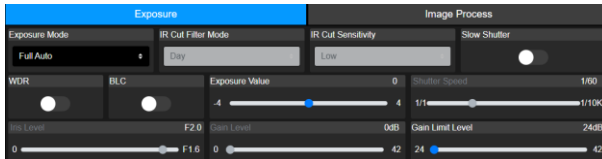

Item	Description
Exposure Mode	Select an exposure mode.
WDR	Turn WDR or BLC on or off.
BLC	
Exposure Value	Adjust exposure, shutter, iris and gain.
Shutter Speed	
Iris Level	
Gain Level	
Gain Limit Level	
IR Cut Filter Mode (MD330UI only)	Select Day mode, Night mode to switch infrared night vision on or off., Or select Auto mode and adjust IR Cut Sensitivity .
Slow Shutter	Turn Slow Shutter on or off.

Image Process

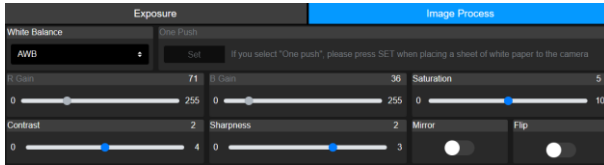

Item	Description
White Balance	<ul style="list-style-type: none">● Select a white balance mode. When Manual is selected, you can also adjust the R Gain and B Gain.● When One Push is selected, place a piece of white paper in front of the camera lens and click Set to calibrate white balance.
Saturation	
Contrast	Adjust saturation, contrast and sharpness.
Sharpness	
Mirror	Turn Mirror or Flip on or off.
Flip	
Noise Filter	Select a noise filtering level.

Video & Audio

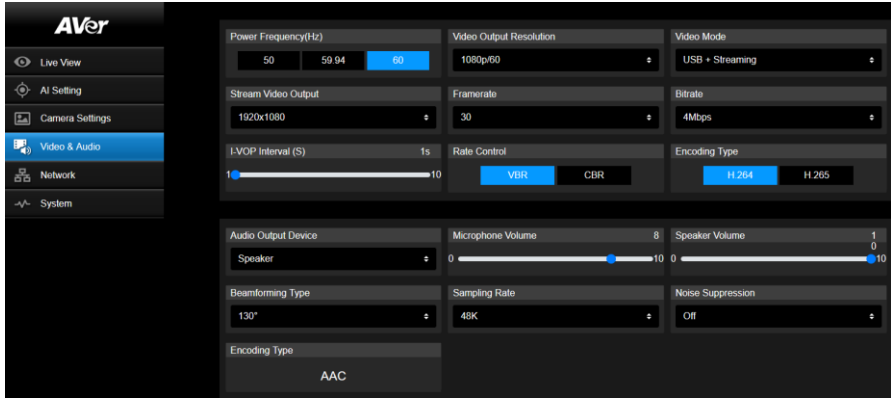

Video Setting

Item	Description
Power Frequency (Hz)	Select 50Hz , 59.94Hz or 60Hz based on your country or region.
Video Out Resolution	Select a video output resolution. RTSP: Max. 4K/30fps HDMI: Max. 1080p 60Hz
Video Mode	Select a video mode. <ul style="list-style-type: none"> ● USB only: Stream video over USB. ● Stream only: Stream video over IP. ● USB + Streaming: Stream video over both USB and IP.
Stream Video Output	Select a streaming output resolution for the live view.
Framerate	Select a framerate
Bitrate	Select a bitrate.
I-VOP Interval (S)	<ul style="list-style-type: none"> ● Drag the slider to choose how often I-VOPs appear in a video stream. ● Shorter I-VOP intervals result in higher video quality but also larger file sizes.
Rate Control	Select VBR or CBR .
Encoding Type	Select H.264 or H.265 .

Audio Setting

Item	Description
Audio Output Device	Select an audio source.
Microphone Volume	Drag the slider to adjust the microphone volume.
Speaker Volume	Drag the slider to adjust the speaker volume.
Beamforming Type	Select a beamforming angle.
Sampling Rate	Select an AAC sampling rate for IP streaming.

Noise Suppression	Select a noise suppression setting. Start with NR before trying other options closer to your use case. <ul style="list-style-type: none"> ● For performance testing, see table below.
Encoding Type	AAC

Noise Reduction Settings	Use Case	Performance*
OFF	Very quiet indoor environment.	Noise is kept.
NR DSP	Indoor environment with low noise.	Noise is reduced
NR (recommended)	Indoor environment with strong background noise, such as a fan.	Noise is further reduced
NR+BF	When it is necessary to limit the range of sound collection with specified angle.	<ul style="list-style-type: none"> ✓ Noise is removed ✗ Might drop a few words
NR Strong	Indoor environment with strong background noise, such as people talking.	<ul style="list-style-type: none"> ✓ Noise is removed ✗ Takes longer to process and reduce unusual sounds ✗ Might drop a few words

*Performance varies due to many factors, including voice to noise ratio, number of speakers, room size, sound source direction, microphone quality, ambient sounds, and so on. Performance was tested under controlled AVer laboratory conditions.

Network

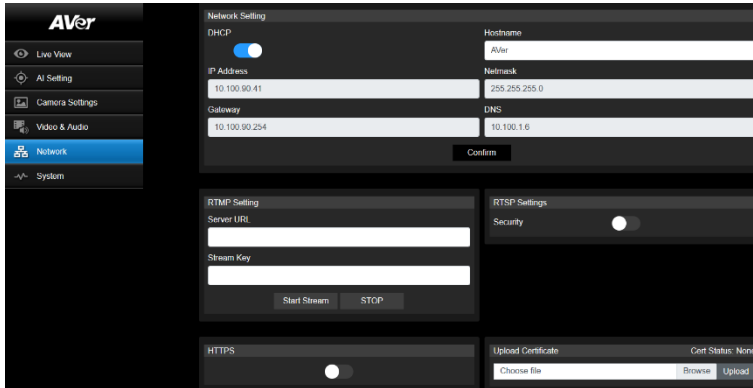

Item	Description
Hostname	The default hostname is AVer. Change the hostname to be displayed on devices such as an IP router.
DHCP	Set the network to DHCP or Static IP. <ul style="list-style-type: none"> ● DHCP: Turn on DHCP and click Confirm to save the setting. The camera will be assigned IP settings automatically. ● Static IP: Turn off DHCP, enter IP Address, Netmask, Gateway and DNS, and click Confirm to save the settings.
RTMP Setting	Stream live video to a video platform such as YouTube. <ol style="list-style-type: none"> 1. Enter the Server URL and Stream Key of your video platform. Please refer to the instruction of your platform to obtain the server URL and stream key. 2. Click Start Stream to start streaming, Stop to stop streaming.
RTSP Settings	Protect your video stream on media players such as VLC, PotPlayer and QuickTime by ensuring that only authorized users can access it. <ul style="list-style-type: none"> ● When Security is turned off: <ol style="list-style-type: none"> 1. Enter your camera's RTSP URL into the media player. 2. RTSP URL: rtsp://[camera IP address]/live_st1 Example: rtsp://192.168.1.100/live_st1 ● When Security is turned on: <ol style="list-style-type: none"> 1. Enter your camera's RTSP URL and username/password into the media player. 2. RTSP URL: rtsp://[username:password]@[camera IP address]/live_st1 Example: rtsp://1:1@192.168.1.100/live_st1

3. username/password: camera's username/password
(web interface login)

HTTPS

Enable HTTPS to establish a secure connection between your browser and your camera. To enable HTTPS access on your camera:

1. Obtain a SSL certificate for encryption and decryption in base-64 encoded format and use a private key in PKCS#8 format (unencrypted).
 2. Package the required certificate content into PEM format. The SSL certificate uploaded to the camera must be in PEM format.
 3. Click **Browse** to select the certificate file, and then click **Upload**.
 4. Turn on HTTPS.
-

System

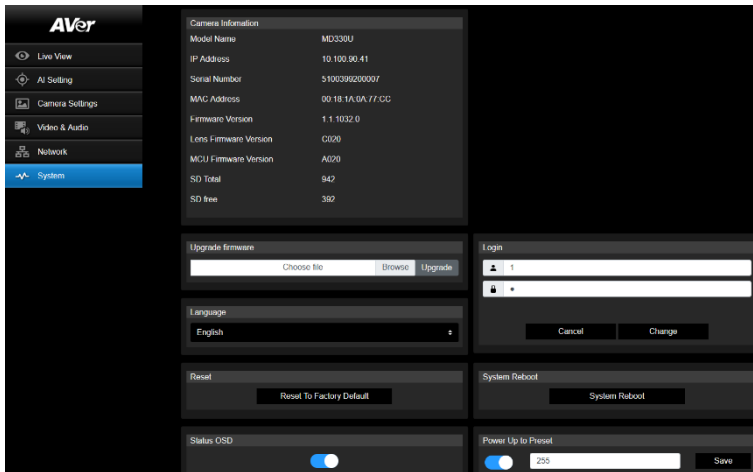

Item	Description
Camera Information	Display camera information.
Upgrade Firmware	Follow these steps to upgrade the firmware: <ol style="list-style-type: none"> 1. Download the latest firmware from the AVer Download Center (https://www.aver.com/download-center/). 2. On the Web page, go to System > Upgrade firmware. 3. Click Browse to select the firmware. 4. Click Upgrade to start upgrading the firmware. 5. Refresh the browser after the upgrade process is complete. <p>[Note] Keep your camera connected to a power source during firmware upgrade. Network connection will be lost during the process and camera will reboot automatically after upgrading.</p>
Login	The default username/password is admin/admin . To change the username/password, enter the new username/password and click Change .
Language	Change the web interface language.
Reset	Reset the camera to factory default settings.
System Reboot	Restart your camera.
Status OSD	Enable to display preset status on the HDMI output during functions such as saving, loading and canceling presets.
Power Up to Preset	When enabled, the camera will move to the defined position after powering on. <ul style="list-style-type: none"> ● Click the toggle to turn on > enter a preset number > click Save. ● Make sure the preset number has been defined before enabling this function.

Power Off to Preset	<p>When enabled, the camera will move to the defined position before powering off.</p> <ul style="list-style-type: none">● Click the toggle to turn on > enter a preset number > click Save.● Make sure the preset number has been defined before enabling this function.
Setting	Export or import your camera settings
USB Function	<p>Select UVC or Mass Storage.</p> <ul style="list-style-type: none">● UVC: Stream video over USB.● Mass Storage: Access the inserted microSD card via USB connection.<ol style="list-style-type: none">1. Connect the camera to a computer using the included USB 3.0 Type-B to Type-A cable.2. Make sure a microSD card has been inserted in the slot.3. On the web interface, go to System > USB Function > select Mass Storage.
Help Us Improve	Opt-in or opt-out of providing anonymous usage data.

AVerCamera Setting Tool

AVerCamera Setting Tool is an application software that supports the operation of AVer PTZ cameras when you stream to a third-party software. It enables users to configure image, audio and video settings without a remote control, as well as connect the camera via USB.

- Download AVerCamera Setting Tool from the AVer website:
(<https://www.aver.com/Downloads/search?q=AVer%20Camera%20Setting%20Tool>).
- For details on settings, see <AVerCamera Setting Tool> in the user manual for CaptureShare.

Specification

Camera	
Image Sensor	1/2.8" Exmor CMOS
Effective Picture Elements	8 Megapixels
Output Resolutions	4K/30 (IP/UVC only), 1080p/60, 1080p/59.94, 1080p/50, 1080p/30, 1080p/29.97, 1080p/25, 720p/60, 720p/59.94, 720p/50, 720p/30
Minimum Illumination	0.7 lux (IRE50, F1.6, 30fps)
S/N Ration	≥ 50dB
Gain	Auto, Manual
Shutter Speed	1/1 to 1/10,000 sec
Exposure Control	Auto, Manual, Priority AE (Shutter, IRIS), BLC, WDR
White Balance	Auto, Manual
Optical Zoom	30X
Viewing Angles	DFOV: 75.5° (Wide) to 3.1° (Tele) HFOV: 68.0° (Wide) to 2.7° (Tele) VFOV: 41.7° (Wide) to 1.5° (Tele)
Focal Length	f = 4.3 mm (Wide) to 129 mm (Tele)
Aperture (Iris)	F = 1.6 (Wide) to 4.7 (Tele)
Minimum Working Distance	Wide: 0.01 m, Tele: 1.2 m
Pan / Tilt Angles	Pan: ±170°, Tilt: +90° / -35°
Pan / Tilt Speed (Manual)	Pan: 0.1° to 100°/sec, Tilt: 0.1° to 100°/sec
Preset Speed	Pan: 200°/sec, Tilt: 200°/sec
Preset Position	10 (IR), 256 (RS-232 / IP)
Camera Control - Protocols	VISCA (RS-232 / IP), PELCO-D & PELCO-P (RS-232), CGI (IP)
Image Processing	Noise Reduction (2D / 3D), Flip, Mirror
Power Frequencies	50Hz / 59.94Hz / 60Hz
Speaker	
Embedded Speaker	Yes
SPL	77 dB SPL (1W; 1m)
Maximum Output	90 dB SPL at 0.5 meter
Microphone	
Built-in Microphone	2 (Omnidirectional)
AI Noise Reduction	Yes
Pickup Range	5 meters
Sensitivity	-33 dBFS
Frequency Response	20 Hz to 20,000 Hz

Maximum SPL	133 dB SPL at 0.5 meter
-------------	-------------------------

Interface	
Video Outputs	HDMI, IP, USB
Audio Outputs	HDMI, IP, USB
microSD Card Slot	Max. 32GB / SDXC
General	
Power Requirement	100-240V AC~ to 12V DC === 3.34A * The included Power Adapter (GSM40A12) is manufactured by MEAN WELL Enterprises Co., Ltd. with Class I classification. ** The power supply is specified as a part of ME EQUIPMENT.
Power Input	12V DC === 3A
Power Consumption	36W
Dimension (W x H x	168 x 205 x 126 mm
Net Weight	1.95kg
Application	Indoor
Tally Lamp	N/A
Security	Kensington Slot
Remote Control	Infrared
Operating Conditions	Temperature: 0°C to +35°C; Humidity: 20% to 80% Atmospheric Pressure: 700 ~ 1060hpa
Storage and Transportation Conditions	Temperature: -20°C to +60°C; Humidity: 20% to 95% Atmospheric Pressure: 500 ~ 1060hpa
IP Streaming	
Resolution	4K, 30fps
Network Video Compress Formats	H.264, H.265
Maximum Frame Rate	4K, 30fps
Network interfaces	10 / 100 / 1000 Base-T
Multi-Stream	2 (RTSP / Web Page), 4K 30fps (max.)
Network Protocols	IPv4, TCP, UDP, ARP, ICMP, IGMP, HTTP, DHCP, RTP / RTCP, RTSP, RTMP, VISCA over IP
Recording	
Cyclic Threshold Rule	Video stream: 720p, 1080p, 4K 32Mbps: 1.3GB 16Mbps: 700MB Others: 500MB

USB	
Connector	USB 3.0
Video Format	MJPEG, YUY2
Audio Format	PCM
USB Video Class (UVC)	Video: UVC1.1 Audio: UAC1.0
Software Tools	
IP Search and Configuration Tool	Support Windows® 7 or later

Specifications are subject to change without prior notice.

Troubleshooting

What does medical grade mean?

It means the MD330U Series camera is certified under IEC 60601-1-2.

This certification guarantees that the MD330 Series camera effectively limits the generation, propagation, and reception of electromagnetic energy. By doing so, it minimizes the risks of undesirable effects like electromagnetic interference (EMI) or physical damage to other operational equipment.

Can I install the camera upside down?

Yes, make sure to shorten the length of the camera head cable by coiling and tying it with a cable tie. Configure Mirror and Flip functions as needed.

How long is the camera head cable?

The length of the cable is 180cm.

Can I use an extension USB cable to lengthen the camera head cable?

No, doing so may damage the camera. Please contact AVer for optional accessories.

Can I disinfect the camera by spraying alcohol on it?

No, please refer to <[How to Clean and Disinfect](#)>.

How to open the on-screen display (OSD) menu?

1. Make sure the HDMI cable is connected to your camera and display.
2. On the remote control, press and hold **Menu**  for 3 seconds to open the OSD menu.
3. A solid purple light on the LED indicator will indicate that the OSD menu is turned on.

The camera suddenly fails to receive my voice and the LED indicator is flashing orange.

- A flashing orange light on the LED indicator indicates that the microphone is muted.
- Upgrade to firmware 1.1.1030.0 or later to avoid video conferencing software, such as Microsoft Teams or Google Meet, from muting the camera when it deems the received volume too high.

Firmware upgrade and rollback.

● To upgrade:

Firmware 1.1.1017.0 or later can upgrade to the latest version.

Firmware 1.1.1016.0 or before must first upgrade to firmware 1.1.1017.0 before upgrading to the latest version.

● To roll back:

The earliest version you can roll back to is firmware 1.1.1015.0.

There is no picture on the output screen.

1. Check all the connectors again as shown in this manual.
2. Verify the setting of the display output device.

The picture on the output screen is distorted or the image is blurry.

1. Reset all changed settings, if any, to the original manufacturer default setting. On the remote control, press **Menu > Factory Default > On**.
2. Use the Brightness and Contrast menu functions to reduce the distortion if applicable.
3. If you discover that the image is blurry or out of focus, click the **Auto Focus** button on the Web setup page (**Live View > Camera Control**).

The voice from the speaker is staticky or with undesired noise.

1. Keep the camera at least one meter away from other electrical equipment.
2. Reset all camera settings to factory default. On the remote control, press **Menu > System > Factory Default > On**.
3. Adjust the **Speaker Volume** and enable the **Noise Suppression** function. On the Web Setup page of the camera, go to **Video & Audio > Audio Setting**.
4. Contact the authorized distributor or the point of purchase if the problem resumes.

The snapshot images cannot be found on the microSD card after pressing the Snapshot button on the detachable camera head or on the remote control.

1. For the Snapshot button on the camera head, try to press the button for more than 1 second as a short press is for focus function.
2. Double check if the microSD card is inserted properly.
3. Double check the specifications and the volume of microSD card, please refer to the <Compatible microSD Cards> chapter.
4. Contact the authorized distributor or the point of purchase if the problem resumes.
5. You can directly access the microSD card with your computer. To do so,
 - a. Connect the camera to your computer using the supplied USB 3.0 Type-B to Type-A Cable.
 - b. On the Web page, go to **System > USB Function**. Select **Mass Storage**.
 - c. You can access the microSD card through your computer now.

Appendix

VISCA RS-232 Command Table

Command Set	Command	Command Packet	Comments
IF_Clear	Broadcast	88 01 00 01 FF	I/F Clear (Clear Visca connection & command buffer queue)
CommandCancel	--	8x 2p FF	p: Socket No. (=1or2)
CAM_Power	On	8x 01 04 00 02 FF	Power OFF to Standby mode
	Off	8x 01 04 00 03 FF	Power ON supported in Standby mode only
CAM_Zoom	Stop	8x 01 04 07 00 FF	Zoom Control
	Tele(Standard)	8x 01 04 07 02 FF	
	Wide(Standard)	8x 01 04 07 03 FF	
	Tele(Variable)	8x 01 04 07 2p FF	p=0 (Low) to 7 (High)
	Wide(Variable)	8x 01 04 07 3p FF	
	Direct	8x 01 04 47 0p 0q 0r 0s FF	pqrs: Zoom Position, MD330U(l): 0x0140~0x54C0
CAM_DZoom	On	8x 01 04 06 02 FF	Digital (Sensor) zoom ON/OFF
	Off	8x 01 04 06 03 FF	
CAM_Focus	Stop	8x 01 04 08 00 FF	Focus Control Each 'Far/Near' needs a 'stop'
	Far (Standard)	8x 01 04 08 02 FF	
	Near (Standard)	8x 01 04 08 03 FF	
	Far (Variable)	8x 01 04 08 2p FF	p=0 (Low) to 7 (High)
	Near (Variable)	8x 01 04 08 3p FF	
	Auto Focus	8x 01 04 38 02 FF	AF ON/OFF
	Manual Focus	8x 01 04 38 03 FF	
	Auto/Manual	8x 01 04 38 10 FF	
	One Push	8x 01 04 18 01 FF	
	Direct	8x 01 04 48 0p 0q 0r 0s FF	pqrs: Focus Position, MD330U(l): 0x0000(wide) ~ 0x4000(tele)
	Near Limit	8x 01 04 28 0p 0q 0r 0s FF	pqrs: Focus Near Limit Position 0001: 0.01m 0002: 1m 0003: 1.5m 0004: 2m

Command Set	Command	Command Packet	Comments
			0005: 3m 0006: 6m 0007: 10m
CAM_AFMode	Normal AF	8x 01 04 57 00 FF	Continuous AF ON
	Zoom Trigger AF	8x 01 04 57 02 FF	Continuous AF OFF, only trigger AF after PTZ done
CAM_WB	Auto	8x 01 04 35 00 FF	Normal Auto
	ATW	8x 01 04 35 04 FF	
	Indoor	8x 01 04 35 01 FF	
	Outdoor	8x 01 04 35 02 FF	
	One Push WB	8x 01 04 35 03 FF	One Push WB mode
	Manual	8x 01 04 35 05 FF	Manual Control mode
	One Push Trigger	8x 01 04 10 05 FF	One Push WB Trigger
CAM_RGain	Reset	8x 01 04 03 00 FF	Manual Control of R Gain
	Up	8x 01 04 03 02 FF	
	Down	8x 01 04 03 03 FF	
	Direct	8x 01 04 43 00 00 0p 0q FF	pq: R Gain
CAM_BGain	Reset	8x 01 04 04 00 FF	Manual Control of B Gain
	Up	8x 01 04 04 02 FF	
	Down	8x 01 04 04 03 FF	
	Direct	8x 01 04 44 00 00 0p 0q FF	pq: B Gain
CAM_AE	Full Auto	8x 01 04 39 00 FF	Automatic Exposure mode
	Manual	8x 01 04 39 03 FF	Manual Control mode
	Shutter Priority	8x 01 04 39 0A FF	Shutter Priority Automatic Exposure mode
	Iris Priority	8x 01 04 39 0B FF	Iris Priority Automatic Exposure mode
CAM_SlowShutter	Auto	8x 01 04 5A 02 FF	Auto Slow Shutter ON/OFF
	Manual	8x 01 04 5A 03 FF	
CAM_Shutter	Reset	8x 01 04 0A 00 FF	Shutter Setting
	Up	8x 01 04 0A 02 FF	
	Down	8x 01 04 0A 03 FF	
	Direct	8x 01 04 4A 00 00 0p 0q FF	pq: Shutter Position

Command Set	Command	Command Packet	Comments
CAM_Iris	Reset	8x 01 04 0B 00 FF	Iris Setting
	Up	8x 01 04 0B 02 FF	
	Down	8x 01 04 0B 03 FF	
	Direct	8x 01 04 4B 00 00 0p 0q FF	pq: Iris Position
CAM_Gain	Reset	8x 01 04 0C 00 FF	Gain Setting
	Up	8x 01 04 0C 02 FF	
	Down	8x 01 04 0C 03 FF	
	Direct	8x 01 04 4C 00 00 0p 0q FF	pq: Gain Position
	AE Gain Limit	8x 01 04 2C 0p FF	p: Gain Position (8 to E: 24db~42db)
CAM_ExpComp	Reset	8x 01 04 0E 00 FF	Exposure Comp Amount Setting
	Up	8x 01 04 0E 02 FF	
	Down	8x 01 04 0E 03 FF	
	Direct	8x 01 04 4E 00 00 0p 0q FF	pq: ExpComp Position
CAM_Backlight	On	8x 01 04 33 02 FF	Back Light Compensation ON/OFF
	Off	8x 01 04 33 03 FF	
CAM_LR_Reverse	On	8x 01 04 61 02 FF	Mirror Image ON/OFF
	Off	8x 01 04 61 03 FF	
CAM_Flip	On	8x 01 04 66 02 FF	Flip ON/OFF
	Off	8x 01 04 66 03 FF	
CAM_Preset	Reset	8x 01 04 3F 00 pp FF	Preset Cancel. pp: Preset Number 0x00~0xFF
	Set	8x 01 04 3F 01 pp FF	Preset Save.
	Recall	8x 01 04 3F 02 pp FF	Preset Load.
CAM_Menu	On	8x 01 06 06 02 FF	Menu Display ON/OFF
	Off	8x 01 06 06 03 FF	
	On/Off	8x 01 06 06 10 FF	
CAM_MenuEnter	--	8x 01 7E 01 02 00 01 FF	Enter Submenu
CAM_NR	--	8x 01 04 53 0p FF	p: Image NR Setting (0:OFF, Level1 to 3)
CAM_WDR	On	8x 01 04 3D 02 FF	Wdr ON/OFF
	Off	8x 01 04 3D 03 FF	

Command Set	Command	Command Packet	Comments
CAM_ICR	On	8x 01 04 01 02 FF	Infrared Mode ON (Night)
	Off	8x 01 04 01 03 FF	Infrared Mode OFF (Day)
CAM_AutoICR	On	8x 01 04 51 02 FF	Auto Infrared mode ON/OFF
	Off	8x 01 04 51 03 FF	
	Threshold	8x 01 04 21 00 00 0p 0q FF	pq: ICR OFF(Day)->ON(Night) threshold level 00: Low; 01: Middle; 02: High
CAM_IDWrite	--	8x 01 04 22 0p 0q 0r 0s FF	pqrs: Camera ID (=0000 to FFFF)
Video Format Change	--	8x 01 7E 01 1E 0p 0q FF	pq
			0x02: 1920x1080P/60
			0x03: 1920x1080P/59.94
			0x04: 1920x1080P/30
			0x05: 1920x1080P/29.97
			0x0B: 1280x720p/60
			0x0C: 1280x720p/59.94
			0x0D: 1920x1080p/50
			0x18: 1920x1080p/25
			0x26: 1280x720p/50
0x27: 1280x720p/30			
IR_Receive	On	8x 01 06 08 02 FF	Infrared remote commander reception ON
Pan-tilt Drive	Up	8x 01 06 01 VV WW 03 01 FF	VV: Pan speed setting 0x01 (low speed) to 0x18 (high speed) WW: Tilt speed setting 0x01 (low speed) to 0x18 (high speed) YYYY: Pan Position 7FFF(170°) to 8000(-170°) (Normalized, CENTER 0000) ZZZZ: Tilt Position 7FFF(90°) to 8000(-35°) (Image Flip: OFF) (Normalized, CENTER 0000)
	Down	8x 01 06 01 VV WW 03 02 FF	
	Left	8x 01 06 01 VV WW 01 03 FF	
	Right	8x 01 06 01 VV WW 02 03 FF	
	UpLeft	8x 01 06 01 VV WW 01 01 FF	
	UpRight	8x 01 06 01 VV WW 02 01 FF	
	DownLeft	8x 01 06 01 VV WW 01 02 FF	
	DownRight	8x 01 06 01 VV WW 02 02 FF	

Command Set	Command	Command Packet	Comments
	Stop	8x 01 06 01 VV WW 03 03 FF	
	AbsolutePosition	8x 01 06 02 VV WW 0Y 0Y 0Y 0Y 0Z 0Z 0Z 0Z FF	
	RelativePosition	8x 01 06 03 VV WW 0Y 0Y 0Y 0Y 0Z 0Z 0Z 0Z FF	
	Home	8x 01 06 04 FF	
	Reset	8x 01 06 05 FF	
Freeze	Freeze On	8x 01 04 62 02 FF	Freeze On Immediately
	Freeze Off	8x 01 04 62 03 FF	Freeze Off Immediately
	Preset Freeze On	8x 01 04 62 22 FF	Freeze On When Running Preset
	Preset Freeze Off	8x 01 04 62 23 FF	Freeze Off When Running Preset
RTMP	On	8x 01 04 A2 02 FF	RTMP ON/OFF
	Off	8x 01 04 A2 03 FF	
Video mode	USB+Stream	8x 01 04 A3 00 FF	Video mode setting
	USB only	8x 01 04 A3 01 FF	
	Streaming only	8x 01 04 A3 03 FF	
Reboot	On	8x 01 04 A4 FF	System reboot
P/T_Spd_Relative_Zoom_Ratio	On	8x 01 04 A6 02 FF	P/T Speed Relative Zoom Ratio ON/OFF
	Off	8x 01 04 A6 03 FF	
Factory Reset	System Factory Reset	8x 01 04 3F 03 00 FF	
Preset Speed	Set Preset Speed	8x 01 06 20 0p FF	p=1 (Low) to 6 (High)
Facial Tracking	On	8x 01 04 7D 02 FF	AI Facial Tracking ON/OFF
	Off	8x 01 04 7D 03 FF	

Inquiry Command	Command Packet	Inquiry Packet	Comments
CAM_PowerInq	8x 09 04 00 FF	y0 50 02 FF	On
		y0 50 02 FF	Off
CAM_ZoomPosInq	8x 09 04 47 FF	y0 50 0p 0q 0r 0s FF	pqrs: Zoom Position
CAM_DZoomModelInq	8x 09 04 06 FF	y0 50 02 FF	D-Zoom On
		y0 50 03 FF	D-Zoom Off
CAM_FocusModelInq	8x 09 04 38 FF	y0 50 02 FF	Auto Focus
		y0 50 03 FF	Manual Focus
CAM_FocusPosInq	8x 09 04 48 FF	y0 50 0p 0q 0r 0s FF	pqrs: Focus Position
CAM_FocusNearLimitInq	8x 09 04 28 FF	y0 50 0p 0q 0r 0s FF	pqrs: Focus Near Limit Position
CAM_AFModelInq	8x 09 04 57 FF	y0 50 00 FF	Continuous AF ON
		y0 50 02 FF	Continuous AF OFF, only trigger AF after PTZ done
CAM_WBModelInq	8x 09 04 35 FF	y0 55 00 FF	Auto
		y0 55 04 FF	ATW
		y0 55 01 FF	Indoor
		y0 55 02 FF	Outdoor
		y0 55 03 FF	One Push WB
		y0 55 05 FF	Manual
CAM_RGainInq	8x 09 04 43 FF	y0 50 00 00 0p 0q FF	pq: R Gain
CAM_BGainInq	8x 09 04 44 FF	y0 50 00 00 0p 0q FF	pq: B Gain
CAM_AEModelInq	8x 09 04 39 FF	y0 50 00 FF	Full Auto
		y0 50 03 FF	Manual
		y0 50 0A FF	Shutter Priority
		y0 50 0B FF	Iris Priority
CAM_SlowShutterModelInq	8x 09 04 5A FF	y0 50 02 FF	Auto
		y0 50 03 FF	Manual
CAM_ShutterPosInq	8x 09 04 4A FF	y0 50 00 00 0p 0q FF	pq: Shutter Position
CAM_IrisPosInq	8x 09 04 4B FF	y0 50 00 00 0p 0q FF	pq: Iris Position
CAM_GainPosInq	8x 09 04 4C FF	y0 50 00 00 0p 0q	pq: Gain Position

Inquiry Command	Command Packet	Inquiry Packet	Comments
		FF	
CAM_GainLimitInq	8x 09 04 2C FF	y0 50 0q FF	p: Gain Limit
CAM_ExpCompPosInq	8x 09 04 4E FF	y0 50 00 00 0p 0q FF	pq: ExpComp Position
CAM_BacklightModelInq	8x 09 04 33 FF	y0 50 02 FF	On
		y0 50 03 FF	Off
CAM_LR_Reverse_Inq	8x 09 04 61 FF	y0 50 02 FF	On
		y0 50 03 FF	Off
CAM_Flip_Inq	8x 09 04 66 FF	y0 50 02 FF	On
		y0 50 03 FF	Off
CAM_NRInq	8x 09 04 53 FF	y0 50 0p FF	p: NR Level
CAM_WDRInq	8x 09 04 3D FF	y0 50 02 FF	On
		y0 50 03 FF	Off
CAM_ICRModelInq	8x 09 04 01 FF	y0 50 02 FF	On (Night)
		y0 50 03 FF	Off (Day)
CAM_AutoICRModelInq	8x 09 04 51 FF	y0 50 02 FF	On
		y0 50 03 FF	Off
CAM_AutoICRThresholdInq	8x 09 04 21 FF	y0 50 00 00 0p 0q FF	pq: ICR OFF(Day)->ON(Night) threshold level 00: Low; 01: Middle; 02: High
CAM_IDInq	8x 09 04 22 FF	y0 50 0p 0q 0r 0s FF	pqrs: Camera ID
CAM_VersionInq	8x 09 00 02 FF	y0 50 ab cd mn pq rs tu vw FF	abcd: Vendor Code, AVer: 2574 mnpq: Model Code, MD330U(I): 0559 rstu: Firmware version (ex: 4025 for 1.1.4025.0) vw: Socket Number (=02)
CAM_MenuModelInq	8x 09 06 06 FF	y0 50 02 FF	On
		y0 50 03 FF	Off
Video Format Inq	8x 09 06 23 FF	y0 50 02 FF	1920x1080P/60
		y0 50 03 FF	1920x1080P/59.94
		y0 50 04 FF	1920x1080P/30
		y0 50 05 FF	1920x1080P/29.97
		y0 50 0B FF	1280x720p/60

Inquiry Command	Command Packet	Inquiry Packet	Comments
		y0 50 0C FF	1280x720p/59.94
		y0 50 0D FF	1920x1080p/50
		y0 50 18 FF	1920x1080p/25
		y0 50 26 FF	1280x720p/50
		y0 50 27 FF	1280x720p/30
IR_Receive	8x 09 06 08 FF	y0 50 02 FF	On
		y0 50 03 FF	Off
Pan-tiltPosInq	8x 09 06 12 FF	y0 50 0Y 0Y 0Y 0Y 0Z 0Z 0Z 0Z FF	YYYY: Pan Position 7FFF(170°) to 8000(-170°) (Normalized, CENTER 0000) ZZZZ: Tilt Position 7FFF(90°) to 8000(-35°) (Image Flip: OFF) (Normalized, CENTER 0000)
CAM_Preset_Inq	8x 09 04 3F FF	y0 50 pp FF	Return the last preset number which has been operated pp:01-FF
Pan-tiltMaxSpeedInq	8x 09 06 11 FF	y0 50 ww zz FF	ww = Pan Max Speed zz = Tilt Max Speed
Freeze_Mode_Inq	8x 09 04 62 01 FF	y0 50 02 FF	On
		y0 50 03 FF	Off
Preset_Freeze_Inq	8x 09 04 62 02 FF	y0 50 02 FF	On
		y0 50 03 FF	Off
RTMP_Inq	8x 09 04 A2 FF	y0 50 02 FF	On
		y0 50 03 FF	Off
Video_mode_Inq	8x 09 04 A3 FF	y0 50 00 FF	USB+Stream
		y0 50 01 FF	USB only
		y0 50 03 FF	Streaming only
P/T_Spd_Relative_Zoom_Ratio_Inq	8x 09 04 A6 FF	y0 50 02 FF	On
		y0 50 03 FF	Off
Preset_Speed_Inq	8x 09 06 20 FF	y0 50 0p FF	p=1 (Low) to 6 (High)
Firmware version	8x 09 36 69 04 FF	y0 50 0p 0q 0r 0s 0t 0u 0v 0w FF	fw_ver: p.q.rstu.vw
Facial Tracking Inq	8x 09 04 7D FF	y0 50 02 FF	On
		y0 50 03 FF	Off

VISCA over IP Settings

PORT

Internet protocol	IPv4
Transport protocol	UDP
Port address	52381

FORMAT

	byte 0	byte 1	byte 2	byte 3	byte 4	byte 5	byte 6	byte 7	byte 8 ~~~ byte 23	
func	Payload type		Playload Length	Sequence number				Payload (1 to 16 bytes)		
data	Value1	Value2	1~16(0x0001~0x0010)	0x00000000 ~ 0xFFFFFFFF				VISCA Packet (see page VISCA)		

Payload type

Name	Value1	Value2	Description
VISCA command	0x01	0x00	Stores the VISCA command.
VISCA inquiry	0x01	0x10	Stores the VISCA inquiry.
VISCA reply	0x01	0x11	Stores the reply for the VISCA command and VISCA inquiry, or VISCA device setting command
VISCA device setting command	0x01	0x20	Stores the VISCA device setting command.
Control command	0x02	0x00	Stores the control command
Control reply	0x02	0x01	Stores the reply for the control command.

CGI Command

CGI List for Video Transmission					
CGI item name	URL	Command	Parameter Name	Parameter value	Description
Get JPEG	/snapshot				1280x720 jpg
Get 4K JPEG	/cgi-bin?OnePush=				Step 1: request 4k snapshot
	n /snapshot?res=4k				Step 2: get 3840x2160 jpg
Get RTSP stream	rtsp://ip/live_st1				

CGI List for Audio					
CGI item name	URL	Command	Parameter Name	Parameter value	Description
Auto Echo Cancel	/cgi-bin?Set=	ado_echo_cancel,3,N		0 ~ 1	0 = OFF, 1 = ON
Noise Suppression	/cgi-bin?Set=	ado_noise_suppression,3,N		0 ~ 4	0 = OFF, 1 = NR DSP, 2 = NR, 3 = NR + BF, 4 = NR Strong
Audio Beam Forming	/cgi-bin?Set=	ado_mic_bf_type,3,N		0 ~ 5	0 = 30°, 1 = 50°, 2 = 70°, 3 = 90°, 4 = 110°, 5 = 130°
Audio In Volume	/cgi-bin?Set=	ado_vol,3,N		0 ~10	0 ~ 10 volume
Audio In Mute	/cgi-bin?Set=	ado_mic_mute,3,N		0 ~ 1	0 = Un-mute, 1 = Mute
Output Type	/cgi-bin?Set=	ado_out_path,3,N		0 ~ 2	0 = Speaker, 1 = HDMI, 2 = Both
Output Volume	/cgi-bin?Set=	ado_spk_gain,3,N		0 ~10	0 ~ 10 volume
Output Mute	/cgi-bin?Set=	ado_spk_mute,3,N		0 ~ 1	0 = Un-mute, 1 = Mute

CGI List for Camera Control					
CGI item name	URL	Command	Parameter Name	Parameter value	Description
up start	/cgi-bin?SetPtfz=	1,0,1			
up end	/cgi-bin?SetPtfz=	1,0,2			
down start	/cgi-bin?SetPtfz=	1,1,1			

down end	/cgi-bin?SetPtfz=	1,1,2			
left start	/cgi-bin?SetPtfz=	0,1,1			
left end	/cgi-bin?SetPtfz=	0,1,2			
right start	/cgi-bin?SetPtfz=	0,0,1			
right end	/cgi-bin?SetPtfz=	0,0,2			
zoom_in start	/cgi-bin?SetPtfz=	2,0,1			
zoom_in end	/cgi-bin?SetPtfz=	2,0,2			
zoom_out start	/cgi-bin?SetPtfz=	2,1,1			
zoom_out end	/cgi-bin?SetPtfz=	2,1,2			
set preset:	/cgi-bin?ActPreset=	1,N			N : position
load preset:	/cgi-bin?ActPreset=	0,N			N : position

CGI List for Various Settings					
CGI item name	URL	Command	Parameter Name	Parameter value	Description
exposure value	/cgi-bin?Set=	img_expo_expo,3,N	value	1 ~ 9	N : value
saturation	/cgi-bin?Set=	img_saturation,3,N	value	0 ~ 10	N : value
contrast	/cgi-bin?Set=	img_contrast,3,N	value	0 ~ 4	N : value
Reboot	GET(Basic Authentication)	/cgi-bin?OnePush=!			
Factory Reset	GET(Basic Authentication)	/cgi-bin?OnePush=d			
RTMP Start streaming	/cgi-bin?Set=	vdo_rtmp_enable,3,1			
RTMP Stop streaming	/cgi-bin?Set=	vdo_rtmp_enable,3,0			
Status get (Model name & mac & FW_VER)	/cgi-bin?GetString=	sys_name&net_mac&sys_fw_version		http://10.100.105.110/cgi-bin?GetString=sys_name&net_mac&sys_fw_version	

Serial No. get	/cgi-bin?GetSerialNumber			http://10.100.105.110/cgi-bin?GetSerialNumber	
uploadwav	/uploadwav/uploadwav?Set=	ado_playback_file,3,N		-1~9 (0~9 for customer)	-1 = OFF, 0 ~ 9 = index
oneclick	/cgi-bin?Set=	ptz_oneclick_x,3,N1 &ptz_oneclick_y,3,N2 &ptz_one_click_spd,3,N3		ptz_one_click_spd 1~24	N1, N2 = X, Y coordinates (1080P, 0,0 at top left) N3=moving speed
IR Cut Filter	/cgi-bin?Set=	img_ircut_filter,3,N		0 ~ 2	0 = Day, 1 = Night, 2 = Auto
IR Cut Filter Sensitivity	/cgi-bin?Set=	img_ircut_sensitivity,3,N		0 ~ 2	0 = Low, 1 = Middle, 2 = High

CGI List for AI Setting					
CGI item name	URL	Command	Parameter Name	Parameter value	Description
Eyes Tracking On/Off	/cgi-bin?Set=	trk_tracking_on,3,N	value	0 / 1	0: OFF; 1: ON
Tracking Preset	/cgi-bin?ActPreset=1,255				Save current pos. for eye tracking preset point.
Timeout to preset	/cgi-bin?Set=	trk_lost_time,3, N	value	3 / 5 / 7 / 10	timeout in seconds
Tracking Site	/cgi-bin?Set=	trk_mode,3,N	value	0 / 1	0: Full face; 1: Eyes
Tracking Range	/cgi-bin?Set=	trk_sensitivity,3,N	value	0 ~ 2	0: Close; 1: Medium; 2: Wide
Eyes Tracking On/Off Get	/cgi-bin?Get=trk_tracking_on				
	- Reply	On trk_tracking_on=1 Off trk_tracking_on=0			
Get detect zone(target frame) number	/cgi-bin?Get=trk_detect_num				
	- Reply	trk_detect_num=X	X: number of target frames, 50 max.		
Get detect zone(target	/cgi-bin?GetGroup=trk_detect_zone				

frame) info	s				
	- Reply	<pre> <trk_detect_zones="trk_num:02 .focus:-1.zone[00]:760,09,222,="" 300.zone[01]:660,540,16,22."<="" pre=""> </trk_detect_zones="trk_num:02></pre>	<pre> focus – current target frame number. zone[NN]: x,y,w,h - 1080P</pre>	<pre> (0,0) at top left, X,Y,W,H is the top left of the target frame. "focus:" is followed by the current target frame number. Example: "-1" indicates no target is being tracked. If 3 targets are being tracked, "focus:" should be followed by either 0, 1, or 2.</pre>	